

AN EXACT SOLUTION FOR THE STATICS AND DYNAMICS OF LAMINATED THICK PLATES WITH ORTHOTROPIC LAYERS

JJARANG FAN and JIANQIAO YE

Department of Applied Mathematics and Mechanics, Hefei University of Technology, Hefei, P.R. China

(Received 24 October 1988; in revised form 5 June 1989)

Abstract—In this study, the three-dimensional state equation for the j th ply of a laminated thick orthotropic plate is established in the local coordinate system according to the knowledge which has been introduced in the paper by Sundara Raja Iyengar and Pandya (1983, *Fiber Sci. Technol.* 18, 19–36). Because all the physical quantities appearing in the state equation are just the compatible quantities of the interfaces, it is extremely convenient to develop the state equation of the whole plate. Furthermore, the number of unknowns included in the final equations has no relationship with that of the plies of the plate. Exact solutions are presented for the statics and dynamics of a three-ply orthotropic thick plates with simply supported edges. Numerical results are obtained and compared with those of Srinivas and Rao (1970, *Int. J. Solids Structures* 6, 1463–1481) and thin plate theory.

INTRODUCTION

In the theory of statics and dynamics of laminated thick plates, transverse shear deformation is so important that some improved formulations which account for the deformation and rotatory inertia have to be introduced in the analysis. Yang *et al.* (1966) have developed a Mindlin-type analysis for laminated plates. Whitney (1969) has extended Reissner's theory to such problems. However, because some assumptions were introduced in the above theories, the fundamental equations of three-dimensional elasticity cannot be exactly satisfied and only part of the nine elastic constants (for orthotropic bodies) can be taken into account in these theories. As a result, the errors in thin and middling plate theories will increase as the thickness increases and have significant effects on the interface stresses of laminates. Hence, we can say that all the theories based on some assumptions are invalid for thick plates.

Giving up any assumptions of stress and displacement models, Vlasov (1957) proposed the Method of Initial Functions (MIF) to analyze the problems of thick plates and shells. Sundara Raja Iyengar and Pandya (1983) applied this method to investigate the bending problems of a rectangular orthotropic plate. They expanded an equation containing differential operators in the form of a Maclurin series of coordinate z . Taking several terms of the series, all the physical quantities, in fact, appear to be polynomials of z in the solving procedure, which means that the original state equation cannot be satisfied.

Adopting the displacement method of elasticity, Srinivas and Rao (1969) analyzed the simply supported laminates of isotropic materials. They then extended the method to thick laminated plates made up of orthotropic layers (Srinivas and Rao, 1970). However, the number of calculations might be too great. Moreover, the number of the simultaneous equations will increase sharply as the number of layers increases. Usually, $6p$ equations should be established, where p is the number of layers.

In the present study, all the fundamental equations of three dimensional elasticity can be exactly satisfied and the nine elastic constants can also be taken into account. The exact solutions for the laminates with arbitrary ratio between thickness and width are given. Regardless of the number of layers, the final equations are always in the form of a set of simultaneous algebraic equations. Obviously, the approach developed in the present study can also be applied to the buckling of a thick orthotropic laminated plate.

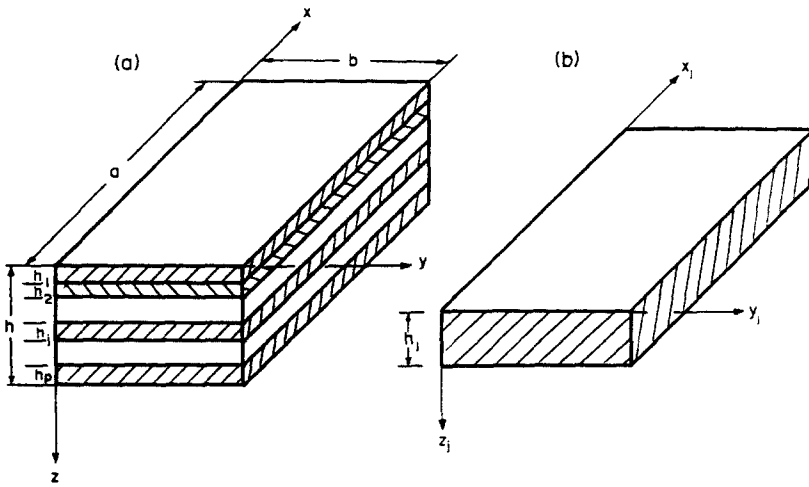

Fig. 1. Coordinate system and dimensions.

BASIC EQUATIONS

A *p*-plyed laminated thick plate made up of orthotropic layers is shown in Fig. 1. The *j*th ply of the plate satisfies the following stress-strain relations :

$$\begin{Bmatrix} \sigma_x \\ \sigma_y \\ \sigma_z \\ \tau_{xy} \\ \tau_{xz} \\ \tau_{yz} \end{Bmatrix}_j = \begin{bmatrix} C_{11} & C_{12} & C_{13} & 0 & 0 & 0 \\ C_{12} & C_{22} & C_{23} & 0 & 0 & 0 \\ C_{13} & C_{23} & C_{33} & 0 & 0 & 0 \\ 0 & 0 & 0 & C_{66} & 0 & 0 \\ 0 & 0 & 0 & 0 & C_{55} & 0 \\ 0 & 0 & 0 & 0 & 0 & C_{44} \end{bmatrix}_j \begin{Bmatrix} \epsilon_x \\ \epsilon_y \\ \epsilon_z \\ \gamma_{xy} \\ \gamma_{xz} \\ \gamma_{yz} \end{Bmatrix}_j \quad (1)$$

The subscript *j* of the matrix denotes that the physical quantities in the matrix corresponding to the *j*th ply. In local coordinates (Fig. 1b), the state equation for the *j*th ply is in the following form :

$$\frac{\partial}{\partial Z} \begin{Bmatrix} U \\ V \\ Z \\ X \\ Y \\ W \end{Bmatrix}_j = \begin{bmatrix} 0 & 0 & 0 & a_{11} & 0 & -\alpha \\ 0 & 0 & 0 & 0 & a_{22} & -\beta \\ 0 & 0 & 0 & -\alpha & -\beta & \xi^2 \\ \xi^2 - C_2\alpha^2 - C_6\beta^2 & -(C_3 + C_6)\alpha\beta & C_1\alpha & 0 & 0 & 0 \\ -(C_3 + C_6)\alpha\beta & \xi^2 - C_6\alpha^2 - C_4\beta^2 & C_5\beta & 0 & 0 & 0 \\ C_1\alpha & C_5\beta & C_{10} & 0 & 0 & 0 \end{bmatrix}_j \begin{Bmatrix} U \\ V \\ Z \\ X \\ Y \\ W \end{Bmatrix}_j \quad (2)$$

where

$$C_1 = -C_{13}/C_{33}, \quad C_2 = C_{11} - C_{13}^2/C_{33}, \quad C_3 = C_{12} - C_{13}C_{23}/C_{33}, \quad C_4 = C_{22} - C_{23}^2/C_{33},$$

$$C_5 = -C_{23}/C_{33}, \quad C_6 = C_{66}, \quad C_{10} = 1/C_{33}, \quad a_{11} = 1/C_{55}, \quad a_{22} = 1/C_{44},$$

$$\alpha = \partial/\partial x, \quad \beta = \partial/\partial y, \quad \xi^2 = \rho \partial^2/\partial t^2, \quad X = \tau_{xz}, \quad Y = \tau_{yz}, \quad Z = \sigma_z,$$

and ρ is the density of the material. The membrane forces can be expressed as (Sundara Raja Iyengar and Pandya, 1983):

$$\begin{Bmatrix} \sigma_x \\ \sigma_y \\ \tau_{xy} \end{Bmatrix}_j = \begin{bmatrix} C_2\alpha & C_3\beta & -C_1 \\ C_3\alpha & C_4\beta & -C_5 \\ C_6\beta & C_6\alpha & 0 \end{bmatrix}_j \begin{Bmatrix} U \\ V \\ Z \end{Bmatrix}_j \quad (3)$$

Considering orthotropic thick laminates with four simply supported edges, the displacements for the j th ply can be chosen to be of the form:

$$\begin{Bmatrix} U \\ V \\ W \end{Bmatrix}_j = \sum_{m=1}^{\infty} \sum_{n=1}^{\infty} \begin{bmatrix} U_{mn}(z) \cos(m\pi x/a) \sin(n\pi y/b) \\ V_{mn}(z) \sin(m\pi x/a) \cos(n\pi y/b) \\ W_{mn}(z) \sin(m\pi x/a) \sin(n\pi y/b) \end{bmatrix}_j e^{i\omega_{mn}t} \quad (4)$$

Substitution of eqn (4) into eqn (2) gives

$$\begin{Bmatrix} X \\ Y \\ Z \end{Bmatrix}_j = \sum_{m=1}^{\infty} \sum_{n=1}^{\infty} \begin{bmatrix} X_{mn}(z) \cos(m\pi x/a) \sin(n\pi y/b) \\ Y_{mn}(z) \sin(m\pi x/a) \cos(n\pi y/b) \\ Z_{mn}(z) \sin(m\pi x/a) \sin(n\pi y/b) \end{bmatrix}_j e^{i\omega_{mn}t} \quad (5)$$

From eqns (3), (4) and (5), it can be noted that the boundary conditions for a simply supported rectangular plate

$$\begin{aligned} & \text{(on } x = \text{constant: } \sigma_x = W = V = 0) \\ & \text{(on } y = \text{constant: } \sigma_y = W = U = 0) \end{aligned}$$

are identically satisfied.

Substituting eqns (4) and (5) into eqn (2) yields for each combination of m and n :

$$\frac{d}{dz} [U_{mn}(z) \quad V_{mn}(z) \quad Z_{mn}(z) \quad X_{mn}(z) \quad Y_{mn}(z) \quad W_{mn}(z)]_j^T$$

$$= \begin{bmatrix} 0 & A_{mn} \\ B_{mn} & 0 \end{bmatrix}_j [U_{mn}(z) \quad V_{mn}(z) \quad Z_{mn}(z) \quad X_{mn}(z) \quad Y_{mn}(z) \quad W_{mn}(z)]_j^T \quad (6)$$

where

$$A_{mn} = \begin{bmatrix} a_{11} & 0 & -\zeta \\ 0 & a_{22} & -\eta \\ \zeta & \eta & -\rho\omega^2 \end{bmatrix} \quad B_{mn} = \begin{bmatrix} -\rho\omega^2 + C_2\zeta^2 + C_6\eta^2 & (C_3 + C_6)\zeta\eta & C_1\zeta \\ (C_3 + C_6)\zeta\eta & -\rho\omega^2 + C_6\zeta^2 + C_4\eta^2 & C_3\eta \\ -C_1\zeta & -C_5\eta & C_{10} \end{bmatrix}$$

$$\zeta = m\pi/a, \quad \eta = n\pi/b, \quad \omega = \omega_{mn}.$$

The solution for a set of differential equations of first order (6) with constant coefficients is

$$\begin{aligned}
 & [U_{mn}(z) \quad V_{mn}(z) \quad Z_{mn}(z) \quad X_{mn}(z) \quad Y_{mn}(z) \quad W_{mn}(z)]_j^T \\
 &= \exp\left(z \begin{bmatrix} 0 & A_{mn} \\ B_{mn} & 0 \end{bmatrix}\right) [U_{mn}(0) \quad V_{mn}(0) \quad Z_{mn}(0) \quad X_{mn}(0) \quad Y_{mn}(0) \quad W_{mn}(0)]_j^T.
 \end{aligned}$$

Simplifying above equation symbolically gives

$$R_j(z) = \exp\left(z \begin{bmatrix} 0 & A \\ B & 0 \end{bmatrix}\right) R_j(0), \quad z \in [0, h_j] \tag{7}$$

where

$$\begin{aligned}
 R_j(z) &= [U_{mn}(z) \quad V_{mn}(z) \quad Z_{mn}(z) \quad X_{mn}(z) \quad Y_{mn}(z) \quad W_{mn}(z)]_j^T \\
 R_j(0) &= [U_{mn}(0) \quad V_{mn}(0) \quad Z_{mn}(0) \quad X_{mn}(0) \quad Y_{mn}(0) \quad W_{mn}(0)]_j^T \\
 A &= A_{mn}, \quad B = B_{mn}.
 \end{aligned}$$

$R_j(0)$, which is called the initial value, is the magnitudes of $R_j(z)$ when $z = 0$. In this way, $R_j(z)$ of the j th ply is expressed in terms of the initial value $R_j(0)$. From the Cayley-Hamilton theorem,

$$\begin{aligned}
 \exp\left(z \begin{bmatrix} 0 & A \\ B & 0 \end{bmatrix}\right) &= \\
 & \begin{bmatrix} \alpha_1(z)I + \alpha_3(z)AB + \alpha_5(z)ABAB & \alpha_2(z)A + \alpha_4(z)ABA + \alpha_6(z)ABABA \\ \alpha_2(z)B + \alpha_4(z)BAB + \alpha_6(z)BABAB & \alpha_1(z)I + \alpha_3(z)BA + \alpha_5(z)BABA \end{bmatrix}
 \end{aligned}$$

where I is a (3×3) unit matrix. $\alpha_s(z)$ ($s = 1, 2, \dots, 6$) are in the form :

$$\begin{bmatrix} \alpha_1(z) \\ \alpha_2(z) \\ \vdots \\ \alpha_6(z) \end{bmatrix}_j = \begin{bmatrix} 1 & \lambda_1 & \lambda_1^2 & \dots & \lambda_1^5 \\ 1 & \lambda_2 & \lambda_2^2 & \dots & \lambda_2^5 \\ \vdots & \vdots & \vdots & & \vdots \\ 1 & \lambda_6 & \lambda_6^2 & \dots & \lambda_6^5 \end{bmatrix}_j^{-1} \begin{bmatrix} e^{\lambda_1 z} \\ e^{\lambda_2 z} \\ \vdots \\ e^{\lambda_6 z} \end{bmatrix}_j$$

in which the λ_s are the eigenvalues of following determinant :

$$\begin{vmatrix} \lambda I & A \\ B & \lambda I \end{vmatrix} = 0.$$

Rewriting eqn (7) in the simplified form below yields

$$R_j(z) = D_j(z)R_j(0); \quad z \in [0, h_j]. \tag{8}$$

In fact, eqn (8) is available to every ply of the plate discussed above. In particular, in the case of $z = h_j$, we have

$$R_j(h_j) = D_j(h_j)R_j(0), \tag{9}$$

where $D_j(h_j)$ is a constant matrix in the given ply of the plate. Equation (9) establishes the relationship between the quantities of the upper surface and lower surface of the j th ply by a constant matrix $D_j(h_j)$. Letting j in eqn (9) equal 1 and p , respectively, we have

$$\begin{aligned}
 R_1(h_1) &= D_1(h_1)R_1(0) \\
 R_p(h_p) &= D_p(h_p)R_p(0)
 \end{aligned} \tag{10}$$

where $R_1(0)$ and $R_p(h_p)$ denote $[U_{mn}(z) \ V_{mn}(z) \ Z_{mn}(z) \ X_{mn}(z) \ Y_{mn}(z) \ W_{mn}(z)]^T$ at the top surface and bottom surface of the plate, respectively.

At the interfaces, the compatibility conditions can be written as

$$R_j(h_j) = R_{j+1}(0) \quad (j = 1, 2, \dots, p-1). \tag{11}$$

Equation (11) shows the equality of the interface stresses and the continuity of the interface displacements.

Starting with the second expression of eqn (10) and using eqns (11) and (9) repeatedly, the following recurrence formula can be obtained :

$$\begin{aligned} [U_{mn}(h) \ V_{mn}(h) \ Z_{mn}(h) \ X_{mn}(h) \ Y_{mn}(h) \ W_{mn}(h)]^T \\ = R_p(h_p) = D_p R_p(0) = D_p R_{p-1}(h_{p-1}) \\ = D_p D_{p-1} R_{p-1}(0) = D_p D_{p-1} R_{p-2}(h_{p-2}) = D_p D_{p-1} \dots D_{j-1} D_j D_{j-1} \dots D_1 R_1(0) \\ = \left(\prod_{j=p}^1 D_j \right) R_1(0) \end{aligned} \tag{12}$$

where $D_j = D_j(h_j)$, and $\prod_{j=p}^1 D_j$ is a (6×6) constant matrix. Considering the entire plate, the quantities of the top and bottom surfaces have been linked together by eqn (12). Usually, X_{mn} , Y_{mn} and Z_{mn} of the top and bottom surfaces are given *a priori*. Actually, eqn (12) is a set of simultaneous equations in terms of surface displacements. Due to the current globe coordinate system shown in Fig. 1a, the displacements of the top and bottom surfaces are uncoupled. In order to determinate the initial values, only a set of three simultaneous equations has to be solved. For instance, if a plate whose top surface is subjected to normal pressure is considered, eqn (12) is in the form

$$\begin{aligned} [U_{mn}(h) \ V_{mn}(h) \ 0 \ 0 \ 0 \ W_{mn}(h)]^T \\ = \left(\prod_{j=p}^1 D_j \right) [U_{mn}(0) \ V_{mn}(0) \ -16q/(mn\pi^2) \ 0 \ 0 \ W_{mn}(0)]^T. \end{aligned} \tag{13}$$

Then, selection of the third, fourth and fifth equations leads to a set of three simultaneous equations in terms of $U_{mn}(0)$, $V_{mn}(0)$ and $W_{mn}(0)$ for each combination of m and n . These can be put in following form :

$$[H][U_{mn}(0) \ V_{mn}(0) \ W_{mn}(0)]^T = \{Q_{mn}\} \tag{14}$$

where H is a (3×3) submatrix of $\prod_{j=p}^1 D_j$, and Q_{mn} in the right-hand side of the equation is a column matrix corresponding to loadings acting on the surface of the plate.

$R_1(0)$ can be obtained when $U_{mn}(0)$, $V_{mn}(0)$ and $W_{mn}(0)$ are determined. Then, substitution of $R_1(0)$ into eqn (12) gives the quantities of the bottom surface. To calculate the displacements and stresses at the interfaces, eqn (9) should be employed to achieve the quantities of the first ply. For the k th ply, it can be observed that the following formulation is advisable :

$$\begin{aligned} R_k(h_k) = D_k D_{k-1} \dots D_1 R_1(0) \\ = \left(\prod_{j=k}^1 D_j \right) R_1(0) \quad (k = 1, 2, \dots, p-1). \end{aligned} \tag{15}$$

The membrane forces of an individual ply, therefore, can be obtained simply by substituting the interface quantities given in eqn (15) into eqn (3). Explicitly, they are discontinuous.

Table 2. Eigenvalue problem of the plate ($mh/a = nh/b = 0.1$)

ρ_1/ρ_2	γ	Present study			Srinivas and Rao (1970)	Thin plate
1	1	0.0475113	0.21700268	0.39405405	0.047419	0.049666
1	2	0.05705221	0.23764351	0.43131167	0.057041	0.060584
1	5	0.07714391	0.29058317	0.52510103	0.077148	0.085333
1	10	0.09810415	0.36111823	0.64697622	0.098104	0.115328
1	15	0.11203228	0.41905859	0.74630609	0.112034	0.138994
3	15	0.094527			0.094548	0.117471

All the calculations in the above procedure are multiplications of matrices which can easily be programmed.

In the eigenvalue problem of free vibration, the exterior lateral surfaces are stress free, that is, $Q_{mn} = 0$. For the non-trivial solution of eqn (14), the determinant of the (3×3) matrix on its left-hand side must be zero. This yields

$$|H| = 0. \tag{16}$$

It should be mentioned that instead of being a polynomial in ω^2 , the characteristic equation (16) appears to be a transcendental equation. In fact, eqn (16) is the exact characteristic equation of a laminated orthotropic thick plate with simply supported edges for each combination of m and n . Each such equation yields an infinite number of eigenvalues. In the analysis herein, the bisection method (Johnston, 1982) is used to treat the equation.

NUMERICAL EXAMPLES

Example 1

Consider a simply supported three-ply laminate loaded only on the top surface by an uniformly distributed normal pressure q . The top and bottom plies of the plate are identical. For each ply, the material properties are indicated below:

$$\begin{aligned} C_{22}/C_{11} &= 0.543103 & C_{12}/C_{11} &= 0.23319 & C_{23}/C_{11} &= 0.098276 \\ C_{33}/C_{11} &= 0.530172 & C_{13}/C_{11} &= 0.01077 & C_{44}/C_{11} &= 0.266810 \\ C_{55}/C_{11} &= 0.159914 & C_{66}/C_{11} &= 0.26293. \end{aligned}$$

Introducing $C_{11}^{(1)}$ and $C_{11}^{(2)}$, which denote C_{11} corresponding to the first and second ply, respectively, and $\gamma = C_{11}^{(1)}/C_{11}^{(2)}$, it can be concluded that in the case of $\gamma = 1$, the plate to be considered is a homogeneous one. Generally ($\gamma \neq 1$), the plate is a sandwich. In Table 1 some results are given in comparison with Srinivas and Rao (1970).

Example 2

We calculate the eigenvalues ($= \omega \sqrt{\rho_2 h^2 / C_{11}^{(2)}}$) of the plate discussed in Example 1. Table 2 gives the first three eigenvalues under a series of γ and density ratio (ρ_1/ρ_2).

All the calculations in Examples 1 and 2 are performed with the following:

$$a = b, \quad a/h = 10, \quad h_1/h = 0.1, \quad h_2/h = 0.8.$$

For the statics ($\omega = 0$), $m, n = 1, 2, \dots, 29$.

CONCLUDING REMARKS

- (1) Besides having concise and clear physical concepts, the method suggested here overcomes the disadvantage which is involved in Srinivas and Rao (1969, 1970), i.e. that the number of equations increases as the plies of the plate increases.

- (2) The method can also be applied to the forced vibration of thick plates and thick laminates.
- (3) For the buckling of thick plates and laminates, the present study is applicable.

REFERENCES

- Johnston, R. L. (1982). *Numerical Methods*. John Wiley, New York.
- Srinivas, S. and Rao, A. K. (1969). Flexure of simply supported thick homogeneous and laminated rectangular plates. *Z. Angew. Math. Mech.* **49**, 449–458.
- Srinivas, S. and Rao, A. K. (1970). Bending, vibration and buckling of simply supported thick orthotropic rectangular plates and laminates. *Int. J. Solids Structures* **6**, 1463–1481.
- Sundara Raja Iyengar, K. T. and Pandya, S. K. (1983). Analysis of orthotropic rectangular thick plates. *Fiber Sci. Technol.* **18**, 19–36.
- Vlasov, V. Z. (1957). The method of initial functions in problems of the theory of thick plates and shells. *9th Int. Cong. Appl. Mech.*, Brussels, **6**, 321–330.
- Whitney, J. W. (1969). The effect of transverse shear deformation on the bending of laminated plates. *J. Comp. Mater.* **3**(3), 534–547.
- Yang, P. C., Norris, C. H. and Stavsky, Y. (1966). Elastic wave propagation in heterogeneous plates. *Int. J. Solids Structures* **2**, 665–684.